



PF-64H SERIES

HIGH HEAD PUMP PACKAGE SYSTEM (150 PSI)

FEATURES

- Designed for applications requiring higher pump head (100' nominal) such as basin sweeper installations or non-chemical water treatment equipment.
- Available in flow rates from 50 to 1,200 GPM.
- Standard unit equipped with PF-61 series separator.
- Cast iron bronze fitted, close-coupled end suction centrifugal pump with TEFC motor.
- Cast iron pre-strainer with removable SST basket.
- Control Panel - NEMA 4X cabinet with door disconnect switch, motor short circuit/overload protection, adjustable purge timer, purge and pump HOA switches.
- Skid - fusion bonded polyester coated carbon steel.
- Sch. 80 PVC interconnecting piping.
- Automatic purge complete with electrically actuated industrial grade ball valve.
- Options: Manual purge, removable dome, 22 1/2" profile separator.



APPLICATION

PUROFLUX's PF-64H high head pump package systems are designed specifically to remove dirt, sand, silt, precipitates, and suspended solids from process fluids.

TYPICAL APPLICATIONS INCLUDE:

- | | | |
|----------------------|-------------------------|------------------------|
| • Cooling Towers | • Well Water | • Industrial Processes |
| • Food Industries | • Waste Water Discharge | • Automotive Processes |
| • Aquatic Exhibits | • Potable Water | • Chemical Processes |
| • Irrigation Systems | • Fish Hatcheries | • Car Washes |

RELIABILITY

The PF-64H package systems are designed to withstand the harshest environments and deliver long lasting reliability. Puroflux utilizes its extensive engineering background in process filtration / separation to provide simple, reliable systems that require minimal maintenance.

SERVICE

Technical field service representatives are available to provide guidance for application, installation and repair in both domestic and international markets.

AFFORDABILITY

PUROFLUX's PF-64H pump package system is an affordable alternative to other comparable types of filtration, and with its low initial investment, offers a quick return on investment.

PF-64H-12_12



PUROFLUX

C O R P O R A T I O N
FILTRATION AND CONTROL SYSTEMS

PF-64H SERIES - High Head Pump Package System (150 PSI)

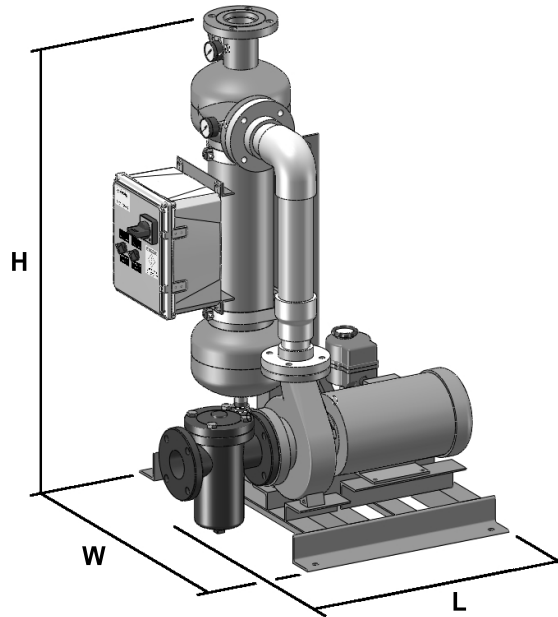

MODEL	FLOW RATE	MOTOR	CONNECTION		PURGE	VOLUME	DIMENSIONS			WEIGHT, LBS	
			Inlet	Outlet			Size	Gallons	L	H	W
PF-64H-012	50	5	2" flng	1.25" mpt	1" fpt	2	40"	42"	30"	377	393
PF-64H-015	80	5	2" flng	1.5" mpt	1" fpt	2	40"	42"	30"	379	395
PF-64H-020	110	7.5	3" flng	2" mpt	1" fpt	7	34"	50"	41"	394	451
PF-64H-025	160	7.5	3" flng	2.5" mpt	1" fpt	8	40"	50"	34"	561	622
PF-64H-030	220	10	3" flng	3" flng	1" fpt	8	40"	51"	36"	592	658
PF-64H-040A	330	15	4" flng	4" flng	1.5" fpt	15	45"	63"	36"	885	1011
PF-64H-040B	400	15	4" flng	4" flng	1.5" fpt	15	45"	63"	36"	945	1072
PF-64H-050	600	20	6" flng	5" flng	1.5" fpt	24	66"	75"	42"	1111	1311
PF-64H-060A	900	30	6" flng	6" flng	1.5" fpt	40	57"	88"	46"	1531	1863
PF-64H-060B	1200	40	8" flng	6" flng	1.5" fpt	40	59"	88"	46"	1963	2295

Consult factory for higher flow rate packages.

TYPICAL INSTALLATION

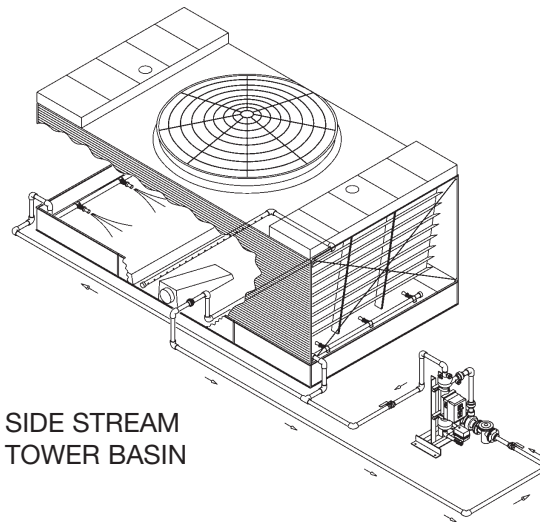

SIDE STREAM
TOWER BASIN



(805) 579-0216 Fax: 579-6005
 website: www.puroflux.com • e-mail: sales@puroflux.com