

## PF-64-060(A)-AP SPECIFICATION SHEET PUMP PACKAGE SYSTEM

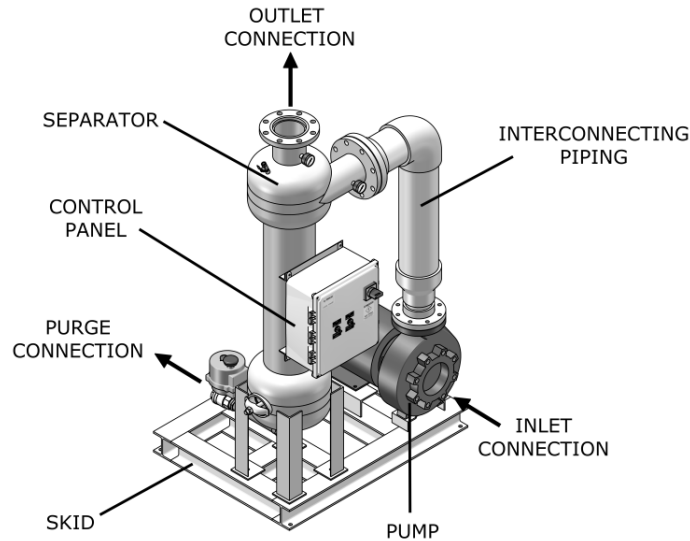

### Features:

- Removes particulate as low as 45 microns
- 150 psi working pressure
- Fully assembled skid package
- One year limited warranty

### Options:

- Manual purge
- Removable dome separator
- 22 1/2° Profile separator
- Coated carbon steel piping
- Isolation valve kit

## SYSTEM COMPONENTS

SPECIFICATIONS	PF-64-060(A)-AP
Flow Rate	900 GPM
System Inlet Connection	6" Flg
System Outlet Connection	6" Flg
Purge Connection	1 1/2" fpt
Separator Model	PF-61-060
Separator Purge	Automatic
Pump Motor	20 HP
Volume	40 GAL
Est. Weight, Dry	1280 lbs
Est. Weight, Operating	1612 lbs

### Separator :

- PF-61 Series separator
- Fusion-bond polyester coated vessel
- Manual air bleed valve
- Inlet/Outlet pressure gauges

### Electrical Controls :

- UL labeled control panel with NEMA 4X Enclosure
- Door disconnect switch
- Short circuit and Motor overload protection
- Hand-Off-Auto switches

### Pump :

- Centrifugal pump
- TEFC motor

### Automatic Purge :

- Electrically actuated ball valve
- Adjustable purge timer

### Skid :

- Fusion-bond polyester coated carbon steel

### Interconnecting Pipe :

- Sch.80 PVC piping

NOTES: UNLESS OTHERWISE SPECIFIED

1. DIMENSIONS ARE IN INCHES
2. DIMENSIONS MAY VARY SLIGHTLY - DO NOT USE FOR CONSTRUCTION
3. SEPARATOR SYSTEM IS RATED FOR 150 PSI WORKING PRESSURE

REVISIONS			
REV	DESCRIPTION	DATE	APPROVED
B	UPDATED COMPONENTS	7-27-16	C.N.

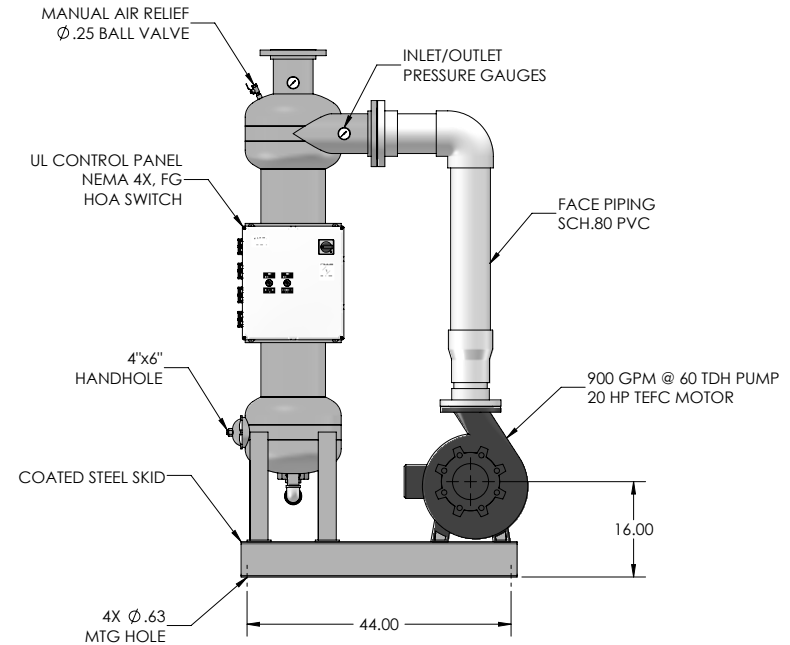
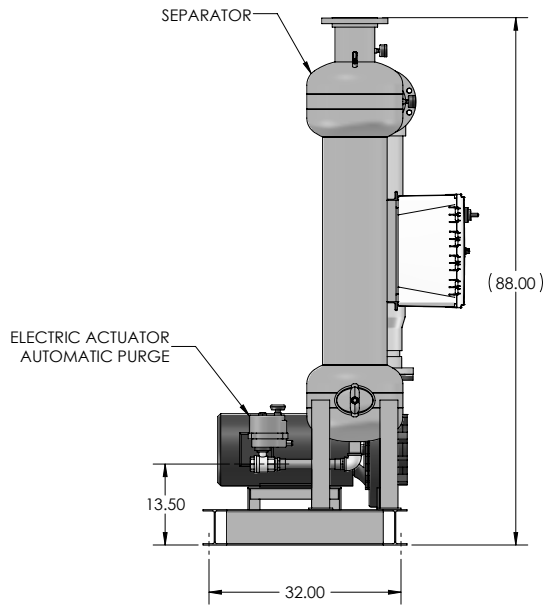
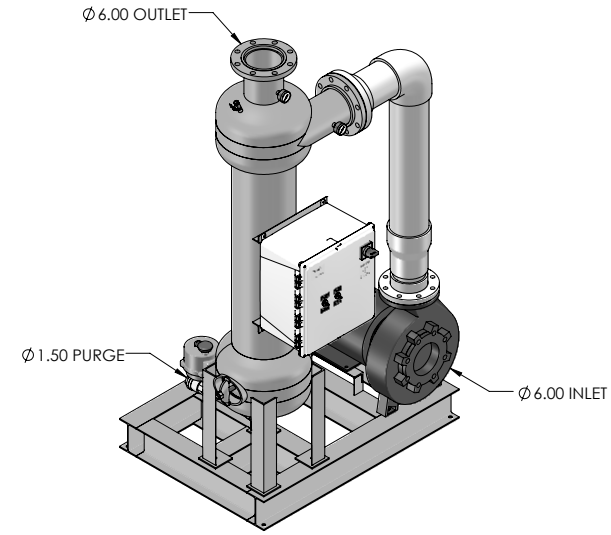
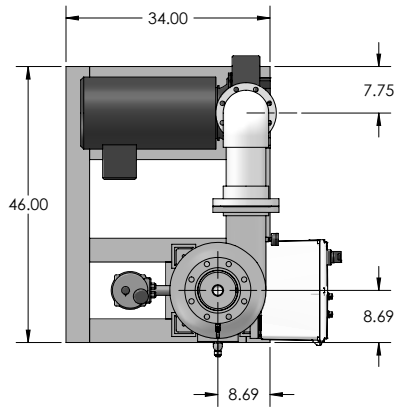

PROPRIETARY AND CONFIDENTIAL THE INFORMATION CONTAINED IN THIS DRAWING IS THE SOLE PROPERTY OF PUROFLUX CORPORATION. ANY REPRODUCTION IN PART OR AS A WHOLE WITHOUT THE WRITTEN PERMISSION OF PUROFLUX CORPORATION IS PROHIBITED.	PF-64-060(A)-AP-UL SEPARATOR PACKAGE 900 GPM - W/SKID MOUNTED PUMP		 <b>PUROFLUX</b> CORPORATION
	SIZE C DWG NO. 641-0288	REV B	
DRAWN D. LUNA	RELEASE DATE 5-28-09	SCALE NONE	SHEET 1 OF 1

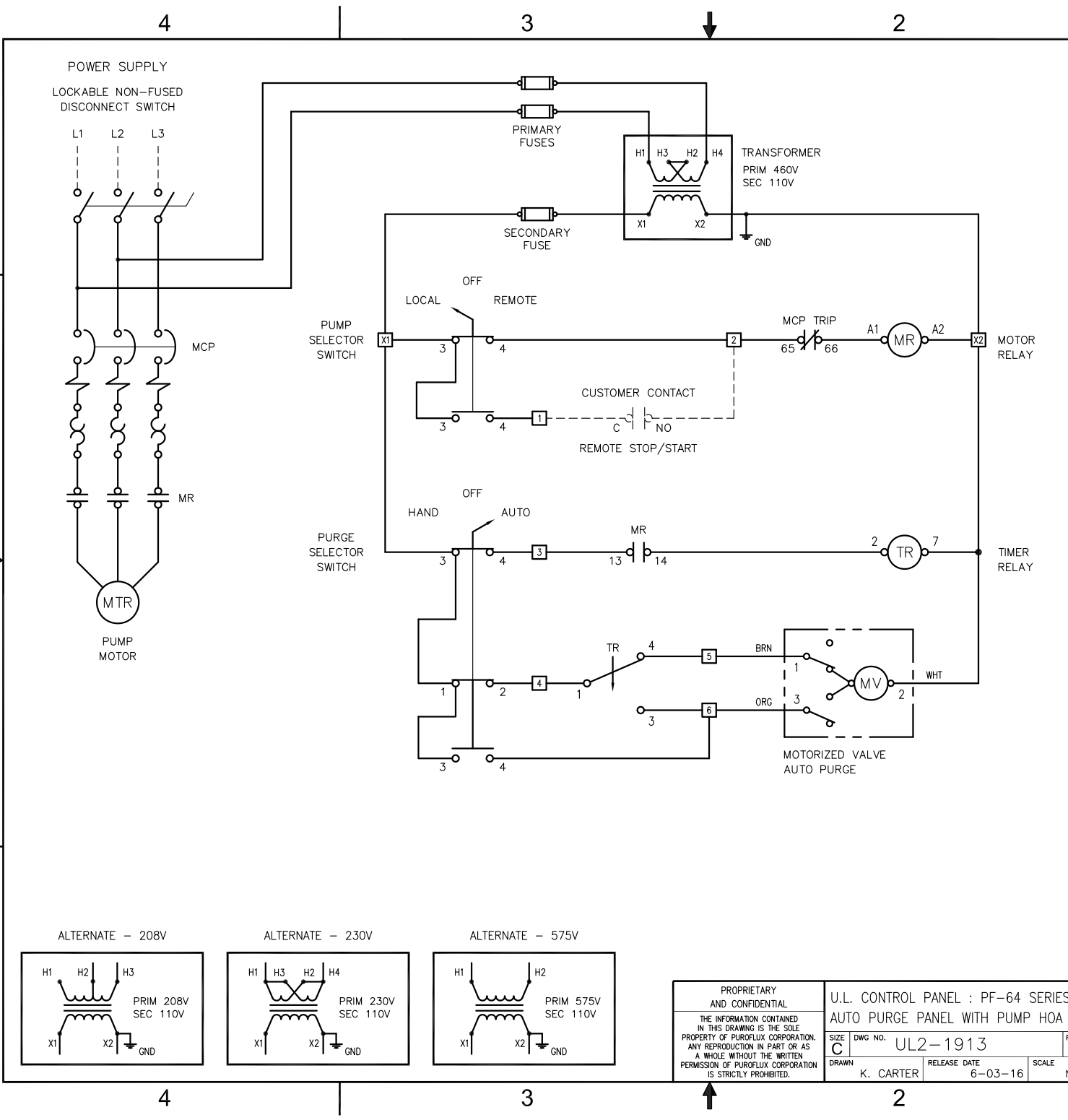

REVISIONS			
REV	DESCRIPTION	DATE	APPROVED

PUMP MOTOR FULL LOAD AMPS ( 3 $\phi$ , 60Hz )				
MOTOR HP	208 VOLTS	230 VOLTS	460 VOLTS	575 VOLTS
10	29.2	25.4	12.7	10.1
15	45.1	39.2	19.6	15.7
20	58.9	51.2	25.6	20.5
25	74.5	64.8	32.4	25.9
30	86.9	75.6	37.8	30.2
40	116.0	101.0	50.4	40.3

FULL LOAD CURRENTS LISTED ABOVE ARE "AVERAGE VALUES" FOR HORSEPOWER RATED MOTORS OF SEVERAL MANUFACTURERS. THE RATED FULL LOAD CURRENT SHOWN ON THE MOTOR NAMEPLATE MAY VARY BY MANUFACTURER.

- NOTES**
- NOTES: UNLESS OTHERWISE SPECIFIED
1. BRANCH CIRCUIT PROTECTION SUPPLIED BY OTHERS
  2. PANEL U.L. LISTED AND LABELED
  3. DASHED LINES INDICATE FIELD WIRING
  4. SWITCH OPERATION  
 "LOCAL" - REMOTE STOP/START OVERRIDE  
 "OFF" - FILTER "OFF"  
 "AUTO" - FILTER ON/OFF VIA REMOTE STOP/STOP

**ACTUATOR WARNING !!!!**

The emergency "MAN" switch and external hand wheel located on the filter actuator are only to be used when there is no power to the actuator. Disconnect power to the control panel before using this feature or **DAMAGE MAY OCCUR** to the actuator.

THIS FEATURE IS FOR EMERGENCIES ONLY!

If the valve does not open or close fully adjust cams to correct problem.

**WARNING**

If an overload or fault current interruption occurs, circuits must be checked to determine the cause of the interruption. If a fault condition exists, the current carrying components should be examined and replaced if damaged, and the integral current sensors must be replaced to reduce the risk of fire or electric shock.

**CAUTION - RISK OF ELECTRICAL SHOCK**

More than one disconnect switch may be required to de-energize the equipment before servicing.

**WARNING - RISK OF FIRE OR ELECTRIC SHOCK**

The opening of the branch circuit protective device may be an indication that a fault current has been interrupted. All current carrying parts and other components protected by this device should be examined and replaced if damaged. If burnout of a current element of an overload relay occurs, the complete overload relay must be replaced.

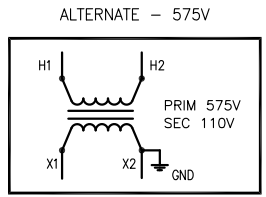
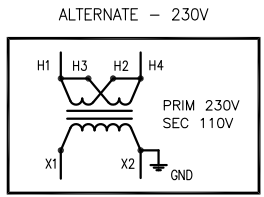
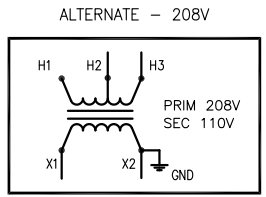

PROPRIETARY AND CONFIDENTIAL

THE INFORMATION CONTAINED IN THIS DRAWING IS THE SOLE PROPERTY OF PUROFLUX CORPORATION. ANY REPRODUCTION IN PART OR AS A WHOLE WITHOUT THE WRITTEN PERMISSION OF PUROFLUX CORPORATION IS STRICTLY PROHIBITED.

U.L. CONTROL PANEL : PF-64 SERIES  
 AUTO PURGE PANEL WITH PUMP HOA

SIZE DWG NO. UL2-1913  
 DRAWN K. CARTER

RELEASE DATE 6-03-16  
 SCALE NONE

**PUROFLUX CORPORATION**

WWW.PUROFLUX.COM

SHEET 1 OF 1