

## PF-63-020 SPECIFICATION SHEET PUMP PACKAGE SYSTEM

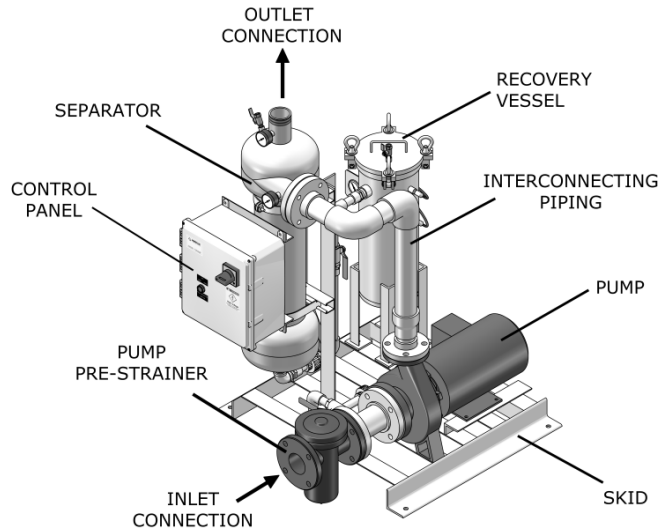

### Features:

- Removes particulate as low as 45 microns
- 150 psi working pressure
- Fully assembled skid package
- One year limited warranty

### Options:

- Removable dome separator
- 22 1/2° Profile separator
- Coated carbon steel piping
- Isolation valve kit
- Dry contact for alarm

### SYSTEM COMPONENTS

SPECIFICATIONS	PF-63-020
Flow Rate	110 GPM
System Inlet Connection	3" Flg
System Outlet Connection	2" mpt
Recovery Vessel Model	PF-RV-1S
Separator Model	PF-61-020
Separator Purge	Continuous
Pump Motor	5 HP
Volume	13 GAL
Est. Weight, Dry	530 lbs
Est. Weight, Operating	640 lbs

### Separator :

- PF-61 Series separator
- Fusion-bond polyester coated vessel
- Manual air bleed valve
- Inlet/Outlet pressure gauges

### Electrical Controls :

- UL labeled control panel with NEMA 4X Enclosure
- Door disconnect switch
- Short circuit and Motor overload protection
- Hand-Off-Auto switches

### Pump :

- Centrifugal pump
- TEFC motor
- Cast iron pre-strainer

### Recovery Vessel :

- 304 Stainless steel vessel
- Pressure differential indicator
- Automatic flow controller

### Skid :

- Fusion-bond polyester coated carbon steel

### Interconnecting Pipe :

- Sch.80 PVC piping

NOTES: UNLESS OTHERWISE SPECIFIED

1. DIMENSIONS ARE IN INCHES
2. DIMENSIONS MAY VARY SLIGHTLY - DO NOT USE FOR CONSTRUCTION
3. SEPARATOR SYSTEM IS RATED FOR 150 PSI WORKING PRESSURE

REVISIONS			
REV	DESCRIPTION	DATE	APPROVED
-			

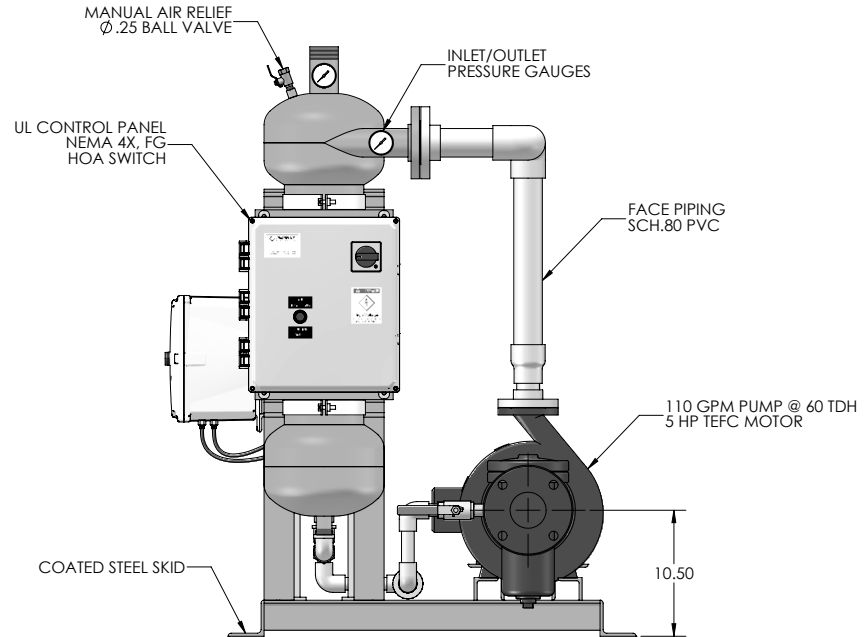
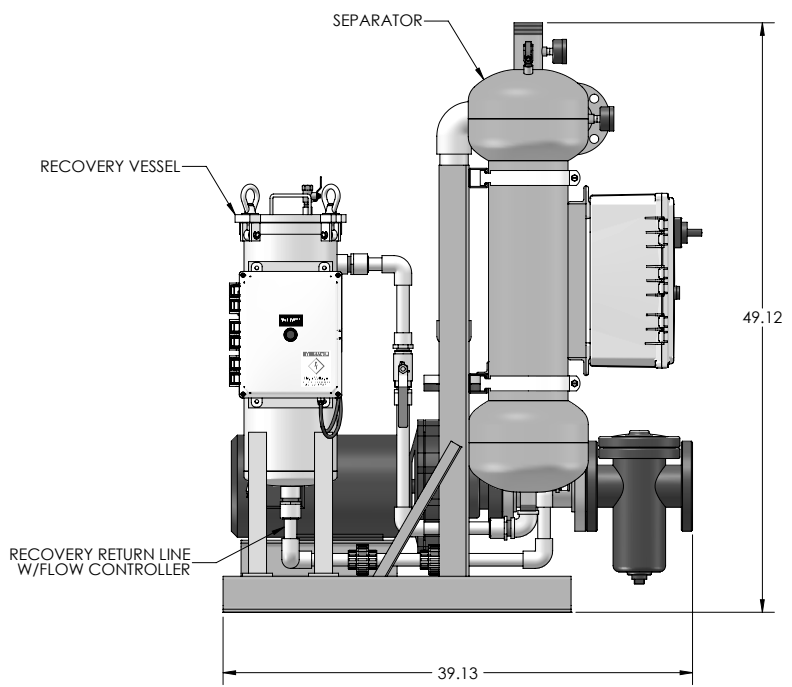
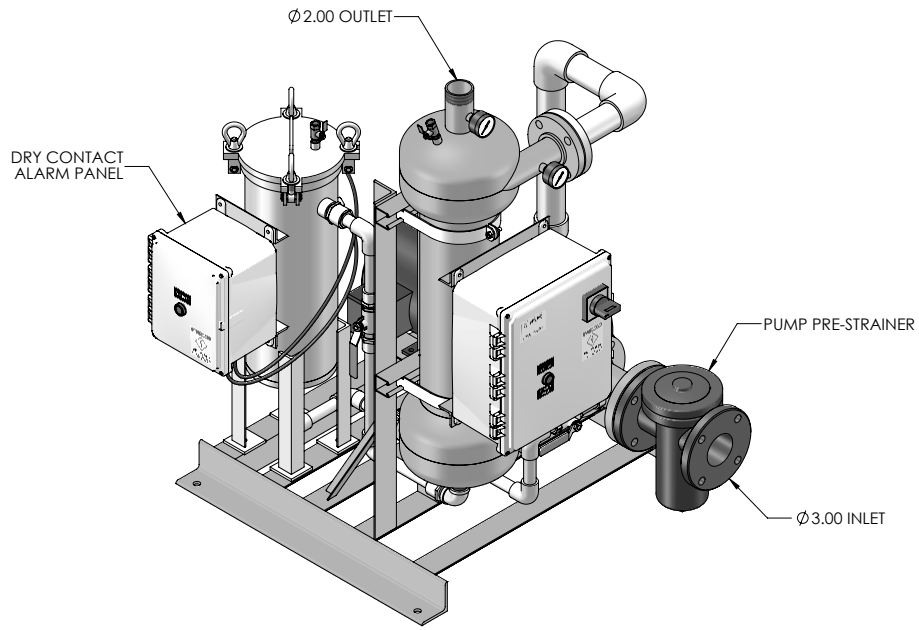
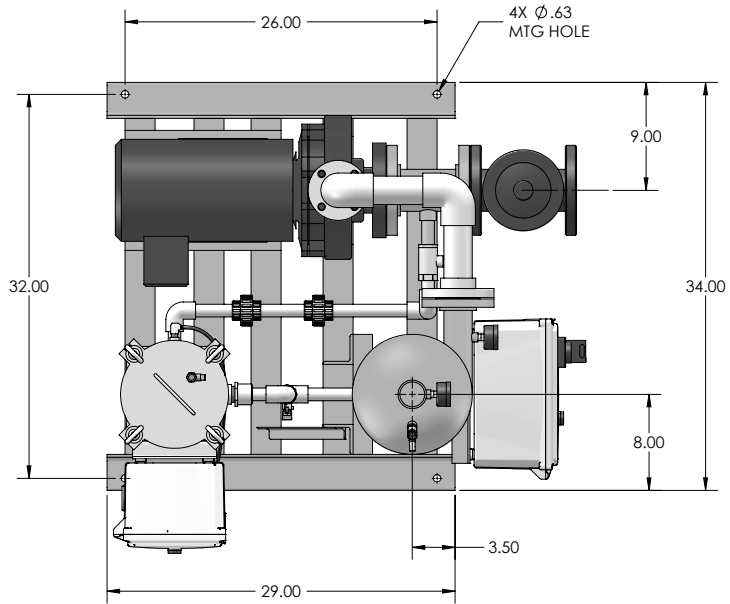

PROPRIETARY AND CONFIDENTIAL THE INFORMATION CONTAINED IN THIS DRAWING IS THE SOLE PROPERTY OF PUROFLUX CORPORATION. ANY REPRODUCTION IN PART OR AS A WHOLE WITHOUT THE WRITTEN PERMISSION OF PUROFLUX CORPORATION IS PROHIBITED.	PF-63-020-DC-UL SEPARATOR PACKAGE 110 GPM - W/RECOVERY VESSEL		 <b>PUROFLUX</b> CORPORATION
	SIZE <b>C</b> DWG NO. <b>631-0308</b>	REV <b>-</b>	
DRAWN <b>D. LUNA</b>	RELEASE DATE <b>7-8-11</b>	SCALE <b>NONE</b>	SHEET <b>1</b> OF <b>1</b>

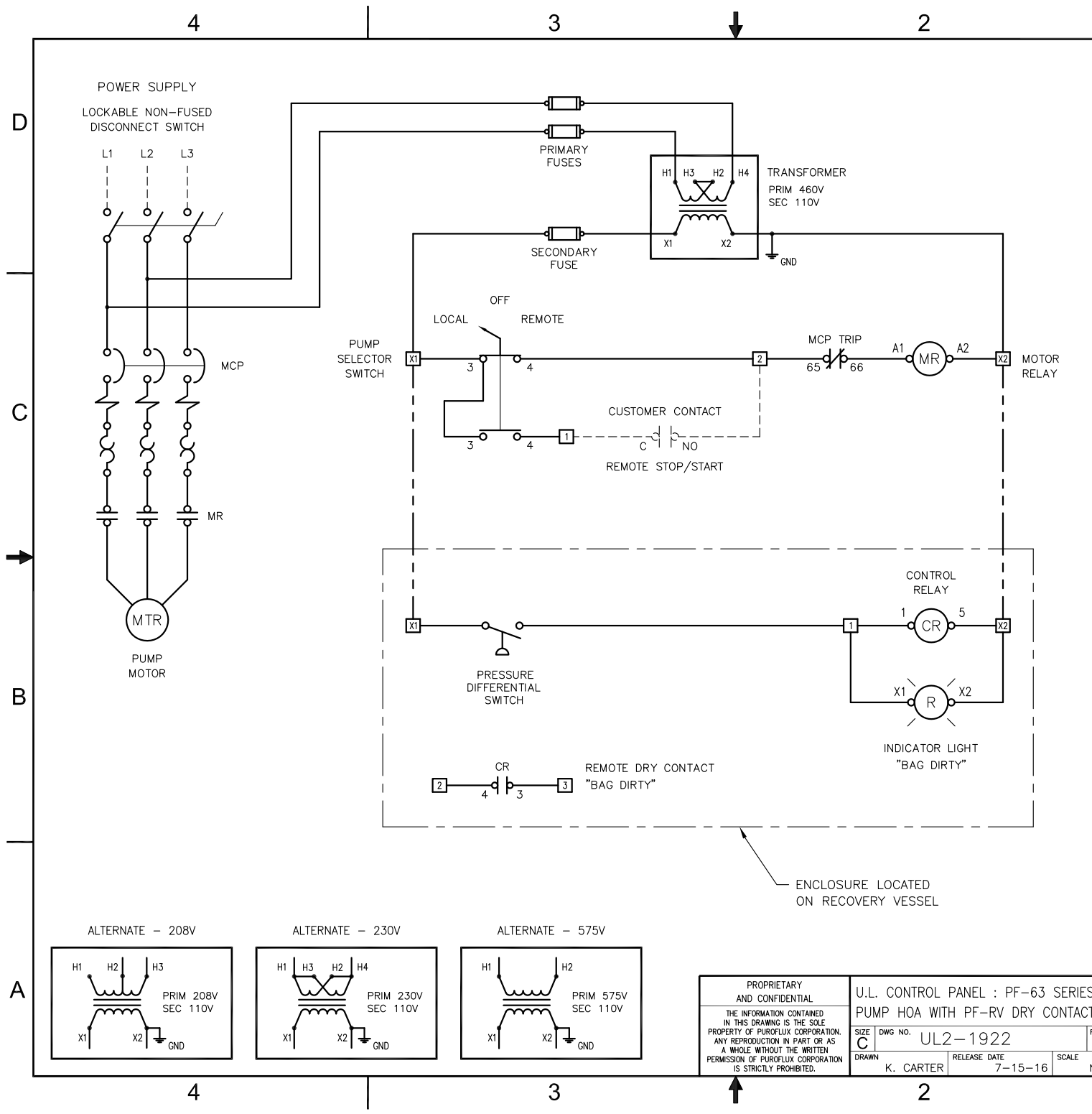

REVISIONS			
REV	DESCRIPTION	DATE	APPROVED

PUMP MOTOR FULL LOAD AMPS ( 3 $\phi$ , 60Hz )				
MOTOR HP	208 VOLTS	230 VOLTS	460 VOLTS	575 VOLTS
2	6.44	5.6	2.8	2.24
3	9.59	8.34	4.17	3.34
5	15.5	13.5	5.76	5.41
7.5	22.4	19.5	9.79	7.81
10	29.2	25.4	12.7	10.1
15	45.1	39.2	19.6	15.7
20	58.9	51.2	25.6	20.5
25	74.5	64.8	32.4	25.9
30	86.9	75.6	37.8	30.2
40	116.0	101.0	50.4	40.3

FULL LOAD CURRENTS LISTED ABOVE ARE "AVERAGE VALUES" FOR HORSEPOWER RATED MOTORS OF SEVERAL MANUFACTURERS. THE RATED FULL LOAD CURRENT SHOWN ON THE MOTOR NAMEPLATE MAY VARY BY MANUFACTURER.

**NOTES**

NOTES: UNLESS OTHERWISE SPECIFIED

- BRANCH CIRCUIT PROTECTION SUPPLIED BY OTHERS
- PANEL U.L. LISTED AND LABELED
- DASHED LINES INDICATE FIELD WIRING
- SWITCH OPERATION  
 "LOCAL" - REMOTE STOP/START OVERRIDE  
 "OFF" - FILTER "OFF"  
 "AUTO" - FILTER ON/OFF VIA REMOTE STOP/STOP

**WARNING**

If an overload or fault current interruption occurs, circuits must be checked to determine the cause of the interruption. If a fault condition exists, the current carrying components should be examined and replaced if damaged, and the integral current sensors must be replaced to reduce the risk of fire or electric shock.

**CAUTION - RISK OF ELECTRICAL SHOCK**

More than one disconnect switch may be required to de-energize the equipment before servicing.

**WARNING - RISK OF FIRE OR ELECTRIC SHOCK**

The opening of the branch circuit protective device may be an indication that a fault current has been interrupted. All current carrying parts and other components protected by this device should be examined and replaced if damaged. If burnout of a current element of an overload relay occurs, the complete overload relay must be replaced.

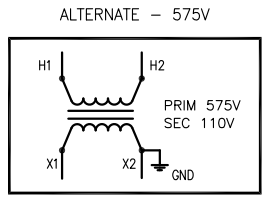
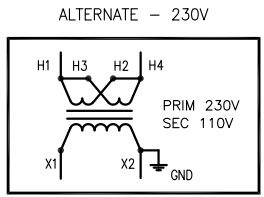
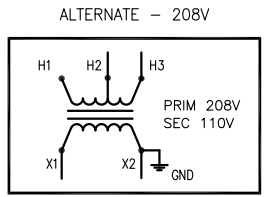

PROPRIETARY AND CONFIDENTIAL

THE INFORMATION CONTAINED IN THIS DRAWING IS THE SOLE PROPERTY OF PUROFLUX CORPORATION. ANY REPRODUCTION IN PART OR AS A WHOLE WITHOUT THE WRITTEN PERMISSION OF PUROFLUX CORPORATION IS STRICTLY PROHIBITED.

U.L. CONTROL PANEL : PF-63 SERIES  
PUMP HOA WITH PF-RV DRY CONTACT

SIZE DWG NO. UL2-1922

DRAWN K. CARTER

RELEASE DATE 7-15-16

SCALE NONE

**PUROFLUX CORPORATION**

WWW.PUROFLUX.COM

SHEET 1 OF 1